



- GSM /GPRS packet transmission and SMS messaging
- Integral GSM 850/900/1800/1900 modem with autonomic GPRS network logon system
- 5 binary/counter inputs with support for potential free contacts (e.g. pulse outputs of water meters)
- Intelligent data logger (max. 28 000 records)
- Built-in temperature sensor
- Optional 1-wire port for external temperature sensor
- Configurable events and schedules initiating measurements and data transmission
- Reed relay for waking up with magnet without opening of the case
- Real Time Clock

- Internal 4.5 VDC alkaline battery pack (S - 3xLR20, M - 6xLR20 or L - 9xLR20) – support for optional 3 VDC and 3,6 VDC lithium packs
- Intelligent power management
- USB port for local configuration
- IP67 enclosure
- Conformal coating for electronics
- -20° to +60°C operating temperature
- Internal GSM antenna or optional SMA connector for external antenna
- User friendly configuration tools and communication driver (OPC and RDB support)
- Support for GPRS based remote management and firmware update

The MT-051 is a battery operated telemetry module optimized for use in alarm systems and flow measuring applications (Automated Meter Reading) where power lines are not available and environmental conditions are harsh (dust, high humidity). MT-051 module is a data logging and transmitting device with the high degree of ingress protection. Like other modules from MT family MT-051 module is a cutting edge design characterized by technological advancement, innovative solutions, ease of configuration and integration with data gathering and processing systems. Module has the possibility of initiating data transmission (event-driven or scheduled) which helps to minimize the transmission costs and energy consumption, therefore increasing battery life. Robust, compact design enclosed in a polycarbonate housing with IP67 protection allows installation and usage of module in places with harsh environment and without power supply (such as water meter pits). The module is powered from alkaline battery packs (optional lithium battery packs). Enclosure dimension indicates

nominal capacity of the battery packs (S size - 3xLR20, M size - 6xLR20, L size - 9xLR20). Voltage level of power source is monitored and transmitted together with measurement data.

MT-051 module is equipped with 5 binary/counter inputs (supporting potential free contacts e.g. pulse outputs of water meter). The MT-051 is compatible with intelligent water meter sensors providing total flow, compensated flow, flow direction, magnetic tampering and cable cut detection signals. The module ensures extremely low power consumption by deactivation of GSM/GPRS modem when there is no data transmission. Measurement data can be recorded in non-volatile Flash memory with precise time stamps. The module is supplied with user-friendly configuration environment and communication driver providing OPC, ODBC and CSV interfaces for data acquisition, and the software for remote management via GPRS, including remote configuration and firmware upgrade.



**5DI / 0DO**



**MT-051**

**General**

Dimensions (H x W x D) in mm:	
MT-051 S	75x125x75
MT-051 M	125x125x75
MT-051 L	175x125x75
Weight (with batteries)	depends on enclosure size and type of battery pack
Mounting method	4 holes
Operating temperatures	-20°C to +60°C
Protection class	IP67

**GSM/GPRS Modem**

Modem type	u-blox LEON-G100
GSM	quad-band (850/900/1800/1900)
GPRS	Class 10
Frequency range:	
GSM 850	Transmitter: 824MHz – 849 MHz Receiver: 869 MHz – 894 MHz
EGSM 900	Transmitter: 880 MHz – 915 MHz Receiver: 925 MHz – 960 MHz
DCS 1800	Transmitter: 1710 MHz – 1785 MHz Receiver: 1805 MHz – 1880 MHz
PCS 1900	Transmitter: 1850 MHz – 1910 MHz Receiver: 1930 MHz – 1990 MHz
Transmitter peak power GSM850/EGSM900	33 dBm (2W) – class 4 station
Transmitter peak power DCS1800/PCS1900	30 dBm (1W) – class 1 station
Antenna	50Ω

**Power**

Alkaline battery pack:	
S size: 3 alkaline batteries	4,5 V / 16 Ah
M size: 6 alkaline batteries	4,5 V / 32 Ah
L size: 9 alkaline batteries	4,5 V / 48 Ah
Mean current consumption with active GSM modem	20 mA (without GPRS transmission)

Maximum frequency of counted pulses	Sleep mode current consumption	
	Typical	Maximum
8 Hz	50 μA	75 μA
256 Hz	150 μA	200 μA

**Binary/pulse inputs I1, I2, I3, I4, I5**

Contacts polarization	2,8 V
Counting frequency (pilot duty 50%)	250 Hz max.
Minimal pulse length - operating in pulse input mode	2 ms
Minimal pulse length - operating in binary input mode	2 ms

**Logger**

Memory type	FLASH
Capacity in records	28000

**Additional features**

Dual SIM	standard SIM and micro SIM/MIM
Internal temperature sensor	Accuracy: ±1°C @ -25°C to +100°C
Port for external temperature sensor 1-Wire DS18B20	Accuracy: ±0,5°C @ -10°C to +85°C ±2°C @ -55°C to +125°C

**Configuration environment**

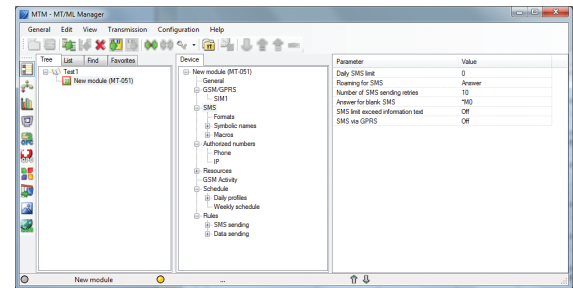

**Drawings and dimensions (all dimensions in millimeters)**

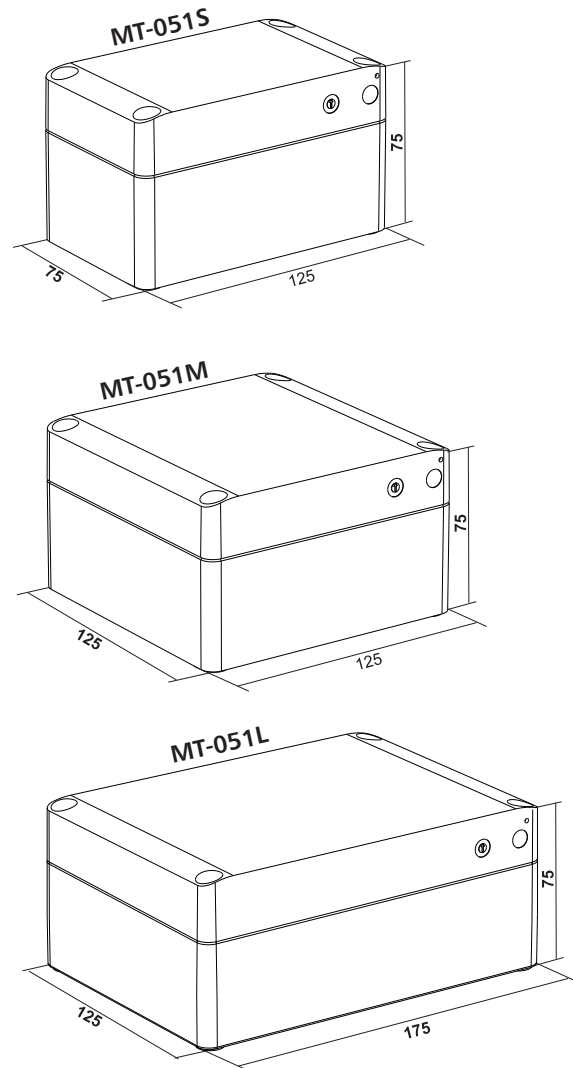

**Supplementary information:**



INVENTIA Sp. z o.o.  
 Poleczki 23, 02-822 Warsaw, POLAND  
 tel.: +48 22 545-32-00, 545-32-01  
 fax: +48 22 643-14-21  
 inventia@inventia.pl, www.inventia.pl



INVENTIA complies with ISO 9001:2015 certified Quality Management System!  
 This project is co-financed by the EUROPEAN UNION from the European Regional Development Fund resources.